

**TABLE: APPURTENANCES INSTALLED ON EXISTING WATERLINE**

**DEMOLITION KEYNOTES**

3	15	EA	REMOVE AND DISPOSE OF EXISTING FIRE HYDRANT ASSEMBLY.
---	----	----	---

**WATERLINE CONSTRUCTION KEYNOTES**

3	1	EA	INSTALL 1" COMBINATION AIR/ VACUUM RELEASE VALVE PER SECTION 400578.13 AND DETAIL 'D' ON SHEET DT01.
6	1	EA	INSTALL 6" DIP GATE VALVE, EPOXY-COATED RESILIENT SEAT (INCLUDING VALVE BOX AND COVER) PER SECTION 331419. ADJUST BOX TO FINISH GRADE PER DETAIL 391-1 AND 391-2 ON SHEET DT02.
22	1	EA	INSTALL 2" BLOWOFF ASSEMBLY PER SECTION 331413. SEE DETAIL 'C' SHEET DT01.
25	15	EA	INSTALL NEW FIRE HYDRANT ASSEMBLY IN ACCORDANCE WITH SECTION 331419 AND DETAIL 'N' ON SHEET DT01. USE MUELLER SUPER CENTURION 250 HYDRANT MODEL A-423 WITH 5-1/4" INLET.

**SECTION A:** BASE BID 'A' INCLUDES WATERLINE & APPURTENANCES ON THE PARALLEL STREETS, ALL 8" LINE AND APPURTENANCES, AND TANK REHABILITATION.

**6" WL & APPURTENANCES ON:**  
 WL1-WL14 (pgs 7-20),  
 WL33 (pg 39),  
 WL52-WL53 (pgs 58-59)

**8" WL & APPURTENANCES ON:**  
 WL16-WL17 (pgs 22-23),  
 WL33 (pg 39),  
 WL29-30 (pgs 35-36),  
 WL38-WL40 (pgs 44-46),  
 WL52-WL53 (pgs 58-59)

**SECTION B:** ALTERNATIVE BID 1 INCLUDES WATERLINE & APPURTENANCES IN THE NORTHVIEW & PANORAMA AREA (AREA WEST OF PARALLEL STREETS), LESS ANY 8" WL & APPURTENANCES.

**6" WL & APPURTENANCES ON:**  
 WL20-WL32 (pgs 26-38),

**SECTION C:** ALTERNATIVE BID 2 INCLUDES WATERLINE & APPURTENANCES IN THE SADDLEROCK AREA (AREA EAST OF THE PARALLEL STREETS), AND MISC PAGES, LESS ANY 8" WL & APPURTENANCES.

**6" WL & APPURTENANCES ON:**  
 KM01 (pg 5),  
 WL18-WL19 (pgs 24-25),  
 WL33 (pg 39, SMALL PORTION HEADING EAST OFF TEE),  
 WL34-WL38 (pgs 40-44),  
 WL41-WL51 (pgs 47-57).

**NOTES:**  
 EXISTING WATERLINE  
 PLAN SHEET MATCHLINES

**FUTURE PHASE LINE NOTE:**  
 Various plan sheets at 89A include new waterline installed on 89A adjacent to a bold line stating "Future Phase Line". Waterline north of this line not included in Project at this time. This portion of waterline may be bid at a future date which is separate from Bid Sections A, B, and C.

**FIRE HYDRANT NOTES:**  
 New proposed fire hydrants= 42.  
 Hydrants installed on new waterline= 27.  
 Hydrants installed on old waterline= 15.  
 "Protect in place" hydrants reconnecting onto new waterline= 9.  
 Total hydrants= 51.

ITEM	FIRE HYDRANTS			TOTAL
	BASE BID	ALT BID 1	ALT BID 2	
103: REMOVE & DISPOSE HYD.	15	3	24	42
110: PROTECT HYD. IN PLACE	4	4	1	9
204: NEW HYD. ON NEW WL	15	3	9	27
223: RECONNECT EXISTING	4	4	1	9
225: NEW HYD. ON OLD WL	0	0	15	15

**WATER METER BOXES:**  
 An estimated 65 concrete meter boxes will need to be replaced in this Project. Replace with non-metal lids. Replacement boxes are listed on the Bid Form, not in plan sheet keynotes.

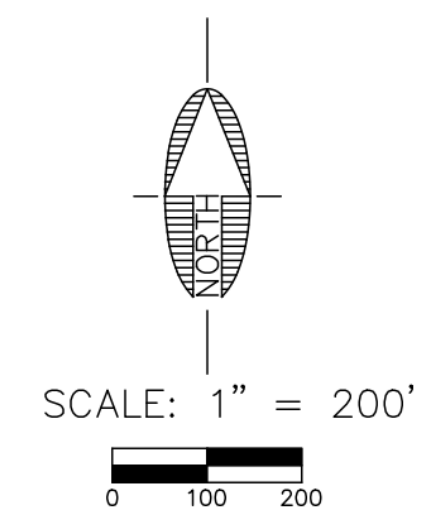

Contact Arizona 811 at least two full working days before you begin excavation

Call 811 or click Arizona811.com

**REVISIONS**

NO.	DESCRIPTION	DATE	BY

75 Kallol Place  
 Sedona, AZ 86336  
 928.282.1061  
 928.282.2058 fax  
 www.swiaz.com

JOB NO: 18169  
 DATE: FEB 23  
 SCALE: 1"=200'  
 DRAWN: JAT  
 DESIGN: JAT  
 CHECKED: JBW

OAK CREEK WATER DISTRICT  
 SEDONA ARIZONA  
 PROJECT BOUNDARY, SHEET KEYMAP, & BID SECTIONS

DRAWING NO. **KM01**  
 SHT NO. 5 OF 59